



Outdoor LED Installation Protection

LED Driver Enclosure Type 3R

Designed for use as a wiring and/or junction box with our 60W, 80W and 100W Xitanium® drivers, our LED Enclosure can protect outdoor installations against rain, sleet and snow, as well as indoor installations against dripping water.

A value-added solution, this enclosure shields an LED system's driver and wiring, providing much needed protection in one versatile SKU. One SKU that simplifies inventory (one component that meets different driver wattage requirements) as well as installation for your varied indoor and outdoor applications.

Compact and convenient outdoor driver protection

- Small size allows mounting flexibility
- Offers protection against dripping water

UL Type 3R Rating

- Meets standards UL50 Type 3R and CSA Type 3R

Long-lasting finish

- Clean commercial white color
- Post-paint wet epoxy on all surfaces

PHILIPS
ADVANCE

Specification Information

Catalog Number	Description	Application
LED1003R15X3	LED 3R Enclosure	<ul style="list-style-type: none"> NEMA 3R Rated Enclosure for Xitanium LED Drivers LED120A0012V50F, LEDINTA0012V50FO, LED120A0024V33F, LEDINTA0024V41FO, & LEDINTA0024V28FO

Installation requirements and wiring considerations

- Enclosure meets NEMA3R, UL-outdoor ratings
- Enclosure must be mounted 12 inches above roof, parapet or horizontal surface
- Enclosure must be mounted in horizontal position with conduit knockouts facing down
- Use screws (enclosed) to attach cover plate to enclosure chassis
- Follow all NEC and local electrical codes
- Wiring used for connections must have insulation rating of 600V/105C or higher
- Input and output wiring must run inside conduit.
- Wiring from a Class 2 output can be run without conduit as long as PLTC type cable is used

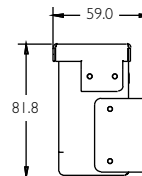
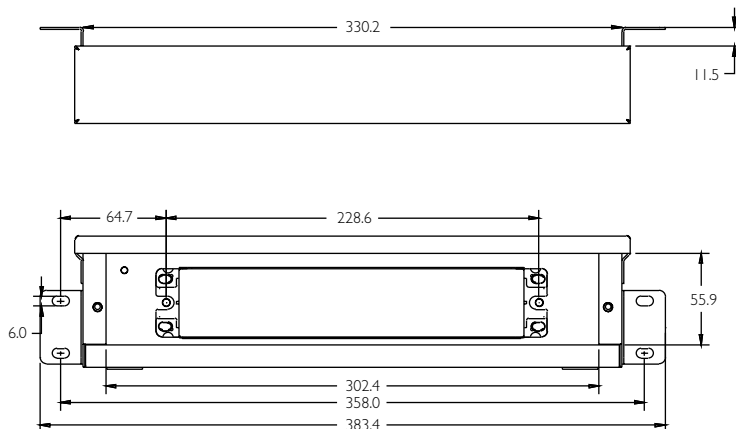
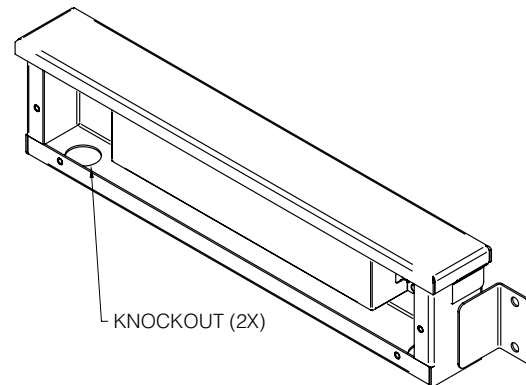
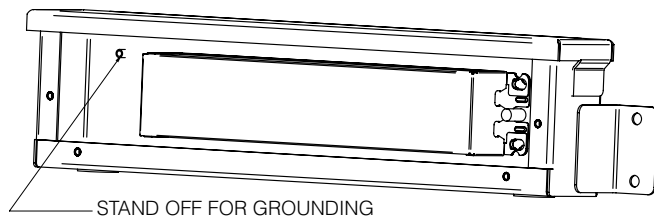

© 2009 Philips Lighting Electronics
All rights reserved.

Form No. LE-6120-R02 10/09

Philips Lighting Electronics
10275 West Higgins Road
Rosemont, IL 60018
Tel: 800-322-2086 Fax: 888-423-1882
Customer Support/Technical Service: 800-372-3331
OEM Support: 866-915-5886
www.philips.com/advance

